



DexROV

DexROV: Dexterous ROV Interventions Supervised from an Onshore Control Center (2 years into the project)

Jeremi Gancet - Space Applications Services (Coordinator – Belgium)
COMEX (France)

Interuniversity center of integrated Systems for the Marine Environment (Italy)

Jacobs University Bremen (Germany)

Idiap Research Institute (Switzerland)

Graal Tech (Italy)

EJR Quartz (Netherlands)

Objectives

1. Reducing the need for large **offshore** crews
=> ROV crew onshore instead

2. Increasing the capability to carry out complex dexterous interventions
=> tasks that only human divers can do so far
=> but doing so also in deep water!

3. Allowing with smaller ROV platforms to perform tasks usually requiring larger ROVs
=> smaller & cheaper support vessel



100-200
kEur/day

16
kEur/day



Main R&D topics – status after 2 years

Perception System (Univ. Jacobs Bremen)

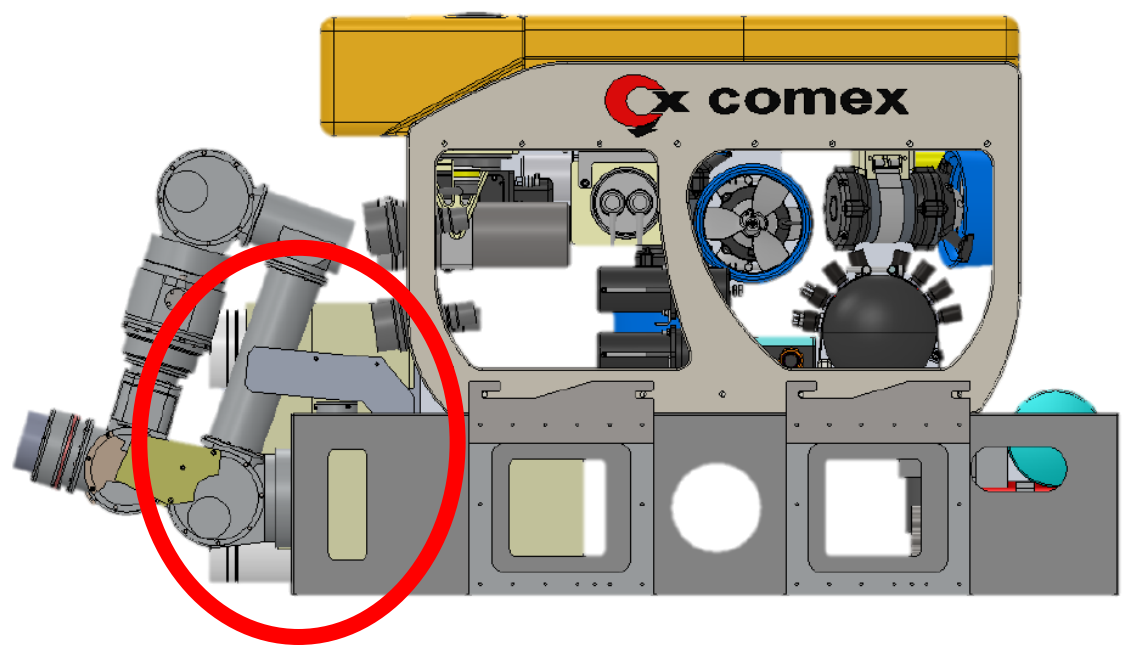
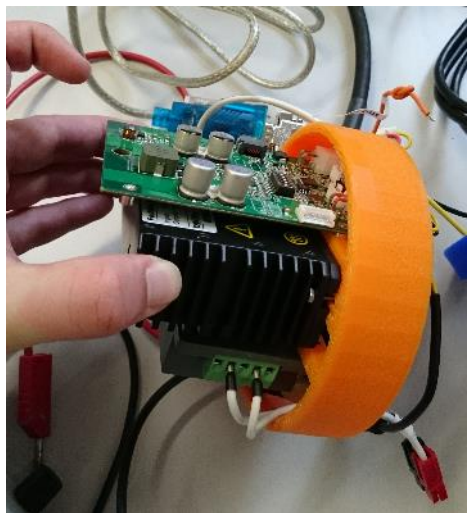

Current perception system prototype (for 2017 trials): vertical stereo bench with 2 cameras (7 kg each)

Main R&D topics – status after 2 years

ROV Control (ISME)

- Task priority framework, addressing navigation + manipulation
- Case study: pipeline inspection task
 - Requires the integration of a force regulation task in the hierarchy
 - Exploits the vehicle velocity tracking compensation
- Current simulation parameters
 - Hydrodynamics
 - Multi rate control
 - Gear reductions modelled
 - Arm torques saturation
 - ...

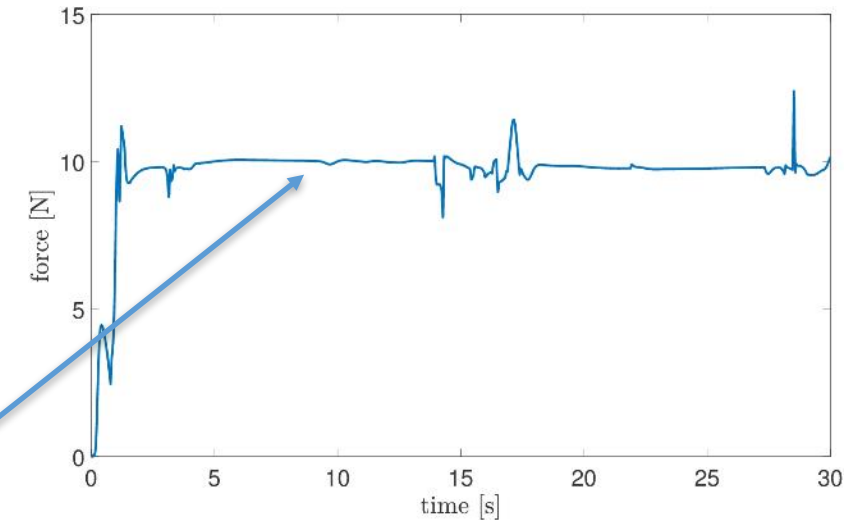

The force regulation is still accomplished

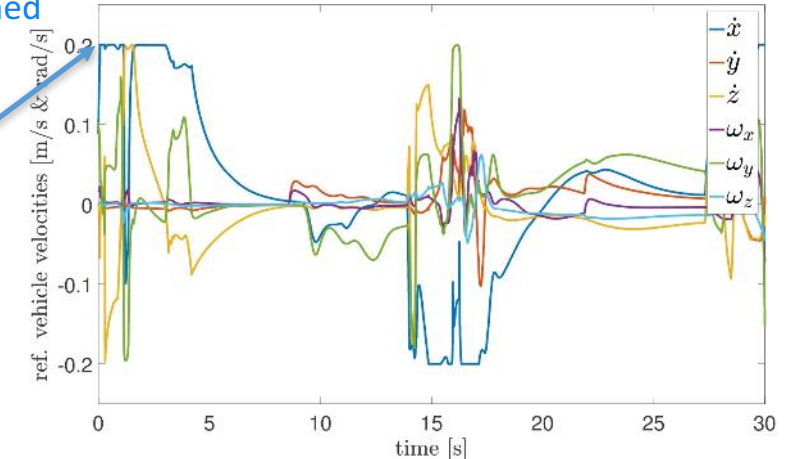

Vehicle velocity request is saturated



Main R&D topics – status after 2 years

Dexterous Manipulator (Graal Tech)

- All internal components available
- First joints assembled and under testing
- To be pressure-checked at 200msw by mid-June
- For 2017 trials, will be equipped with a fake (passive) end-effector

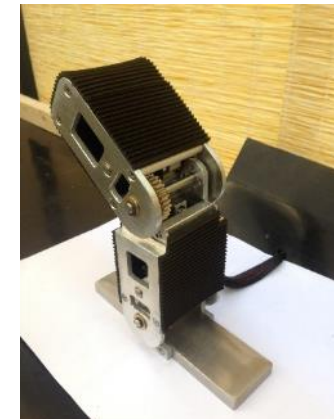
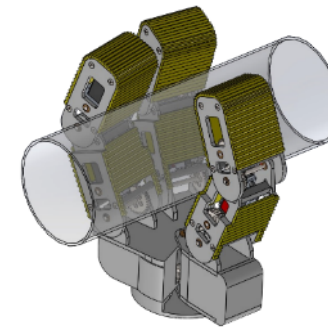
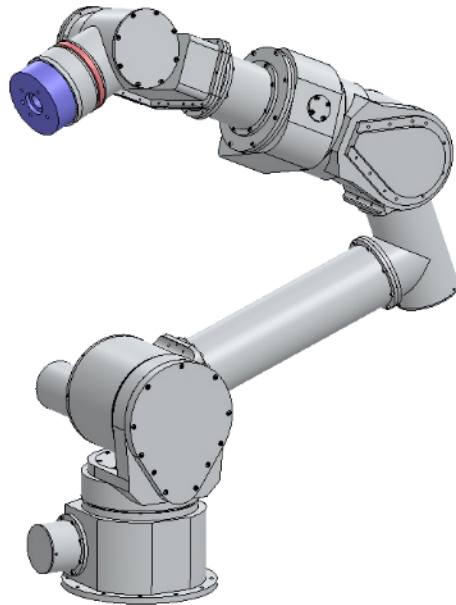

EMRA 2017, Girona, May 15th

Main R&D topics – status after 2 years

Skid (Graal Tech)

- Skid design and components integration consolidated
=> ~150 kg (all buoyant compensated)

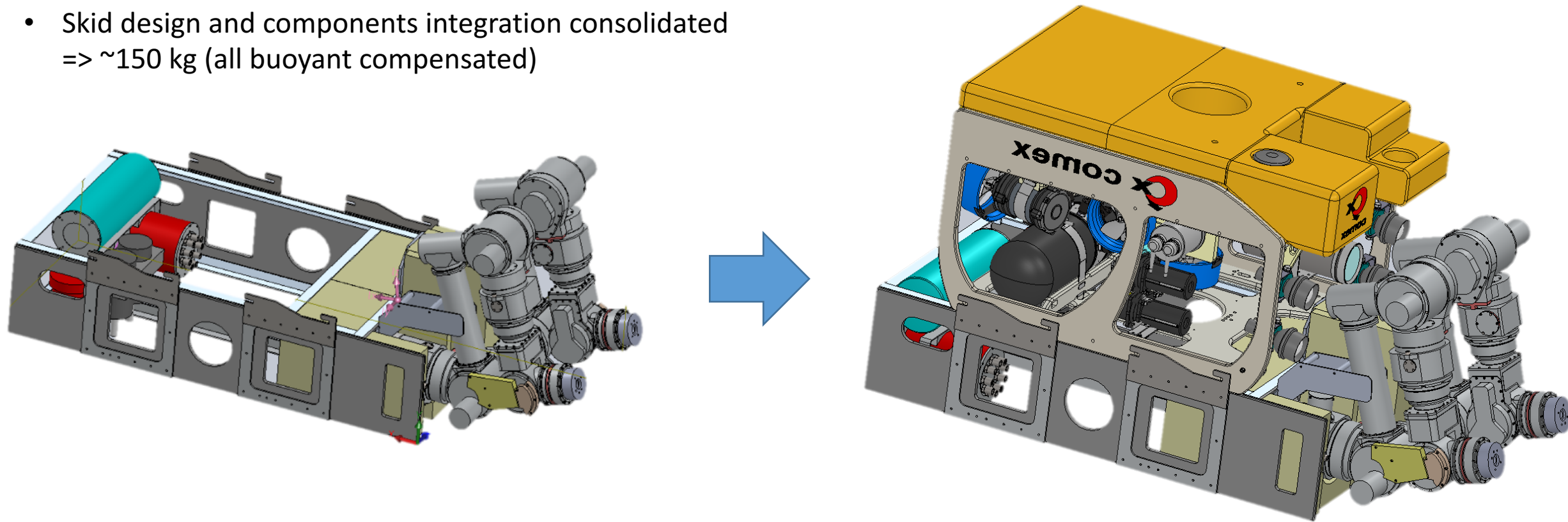

Main R&D topics – status after 2 years

Monitoring and Control Center (SPACEAPPS)

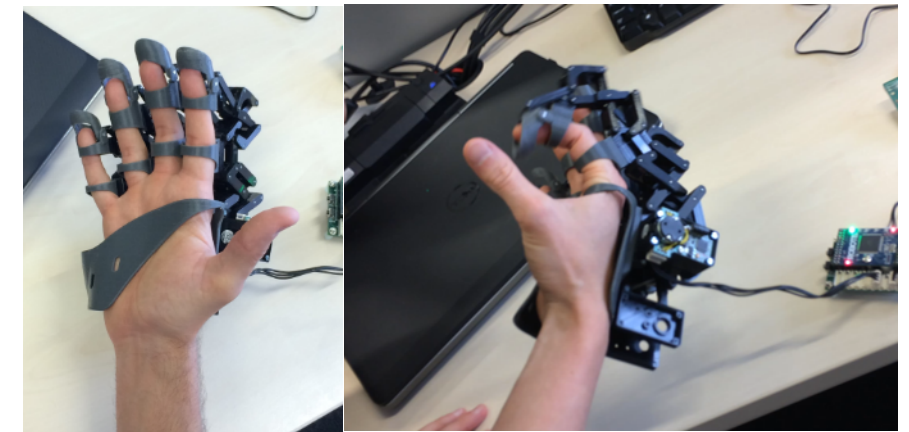
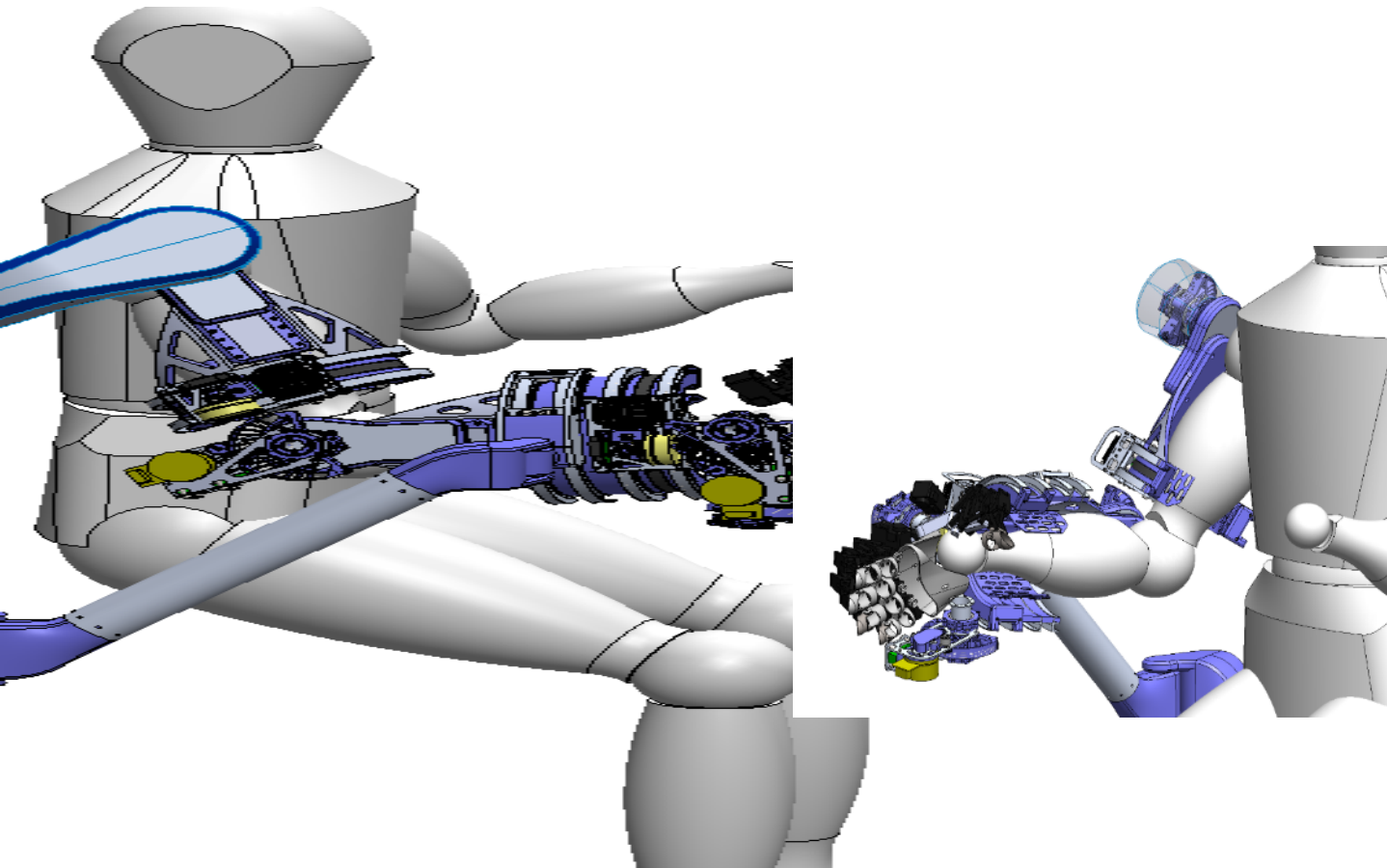

Main R&D topics – status after 2 years

Testbed for trials (COMEX)

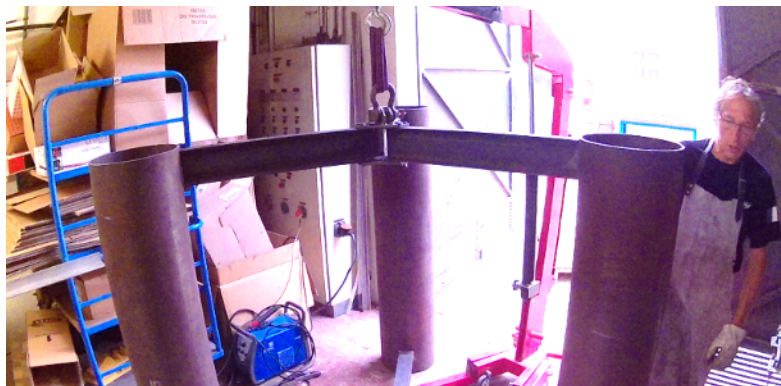

June 2016 - 1st campaign (2nd one coming soon => June/July 2017)

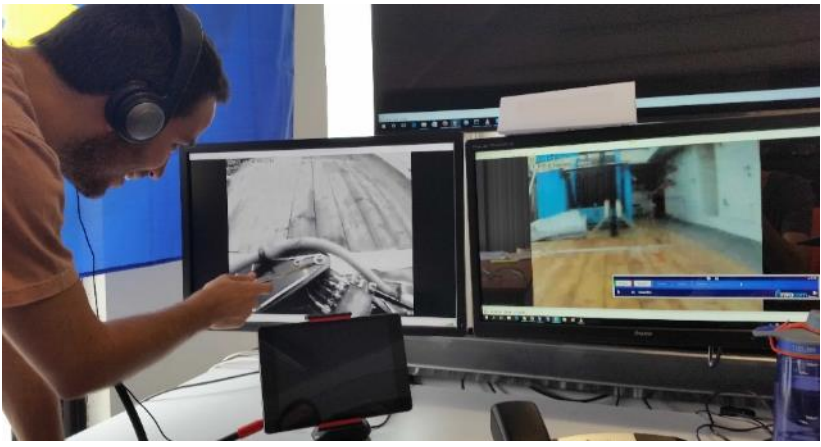



www.dexrov.eu



Contact: info@dexrov.eu

Coordinator: jeremi.gancet@spaceapplications.com